

Combined Spam Filter with Bayesian Filter and SVM Filter

Ayahiko Niimi¹, Hirofumi Inomata¹, Masaki Miyamoto¹, and Osamu Konishi¹

Department of Media Architecture, Future University-Hakodate
116-2 Kamedanakano-cho, Hakodate 041-8655, JAPAN
{niimi, okonishi}@fun.ac.jp

Abstract. In this paper, the system that classified spam mail and other mail(regular mail) was constructed by two filters with Bayesian theory and SVM(Support Vector Machine) used well by the text classification task as a text classification algorithm. It was confirmed to evaluate the performance of the spam filter constructed by Bayesian theory and SVM, and to show a high reproduction ratio and a high relevance ratio. Moreover, the URL pre-fetch method was built into Bayesian spam mail filter, and the relevance ratio was able to be improved. We proposed the spam filter system by the combination of some filters, and discussed the system that added URL pre-fetch method to Bayesian spam filter and the SVM filter.

1 Introduction

Recently, the use of mail service has become popular because the Internet has become popular. The spam mail problem becomes a serious problem along with these popular mail services. The spam mail is a trouble mail that sent to many persons, and the mail so on by one-sided advertising mail, the chain mail, the fictitious claim mail, and included computer virus spread by mail. The spam mail becomes a problem because an increase in the network traffic occurs because other mail not only is buried by a large amount of spam mail but also a large amount of mail flows on the network. Therefore, there is a possibility to exert the influence also in other Internet services. The mechanism that only necessary E-mail is automatically taken out of a large amount of mail including the spam mail is needed because of the spam mail measures.

Because the content of mail is basically described by the text it can be said that task of classifying mail into spam mail and other mail is text classification task. Therefore, various text classification algorithms can be applied for the mail classification task. Especially, spam mail and other E-mail (we define them as regular mail) are thought to be a classification task to two classes with positive examples and negative examples.

In this paper, the system that classified spam mail and other mail was constructed by two filters with Bayesian theory [1] and SVM(Support Vector Machine) [2] used well by the text classification task as a text classification algorithm. Moreover, URL pre-fetch method was added to Bayesian spam filter, and

the performance was evaluated. In addition, we proposed the spam filter system by the combination of some filters, and the system by the combination of Bayesian filter, SVM filter, and URL pre-fetch method[3] was discussed.

2 Combination of Spam Filters

We propose to combine some spam filters to construct the spam mail filter system. Constructing the filter of high accuracy becomes possible by combining spam filters. Moreover, more flexible operation becomes possible, and possibilities stubborn as for the over-learning of the filter are higher than possibilities stubborn of filter which operates with a single learning filter.

In this paper, we discuss the spam filter system by the combination of Bayesian filter, SVM filter, and URL pre-fetch method[3].

The proposed system is required to operate as POP proxy. The purpose of this is to keep using the mail reader usually used. It is possible that a high-speed server for E-mail proxy is prepared, and some user process it by the batch, but there is a problem of no reflection of the each user's learning in the filter easily. When the user who receives about 200-300 mail in a day is assumed, it seems that it operates enough at a practicable processing speed because both Bayesian filter and SVM filter are comparatively high-speed filters. The processing time of the filter of one time becomes shorter time because the heavy user will check to the server to confirm mail frequently.

The flow of operation is as follows. First of all, mail is filtered by Whitelist filter and blacklist filter. URL pre-fetch method is applied for the mail that was not able to be filtered whilelist and blacklist. The system accesses the site when URL is found in mail, and the data is added to mail. Next, the written language is judged, and the word division is operated. Using the algorithm that specializes in a specific language for the algorithm of the word division becomes possible by judging the language. Moreover, possibility of learning speed of filter to slow down can be prevented by language judging, because other languages to become a noise when some languages are learned with one filter. The classified mail result by SVM filter and Bayesian filter is added to the mail header. Processing that distributes mail will be actually processed with the mail reader.

The flowchart of proposed combined spam filter is shown in Figure 1.

3 Implementation of Spam Filter

We implemented the Bayesian spam filter and the SVM spam filter, and evaluated the performances.

We implemented the Bayesian spam filter, and evaluated the performance. Bsfiler[4] was used as a Bayesian spam filter. The Japanese tokens were used two consecutive Chinese characters and katakana(bigram). 150 Regular mail and 150 spam mail (Japanese, English) were prepared, and the performance was evaluated by the cross-validation method.

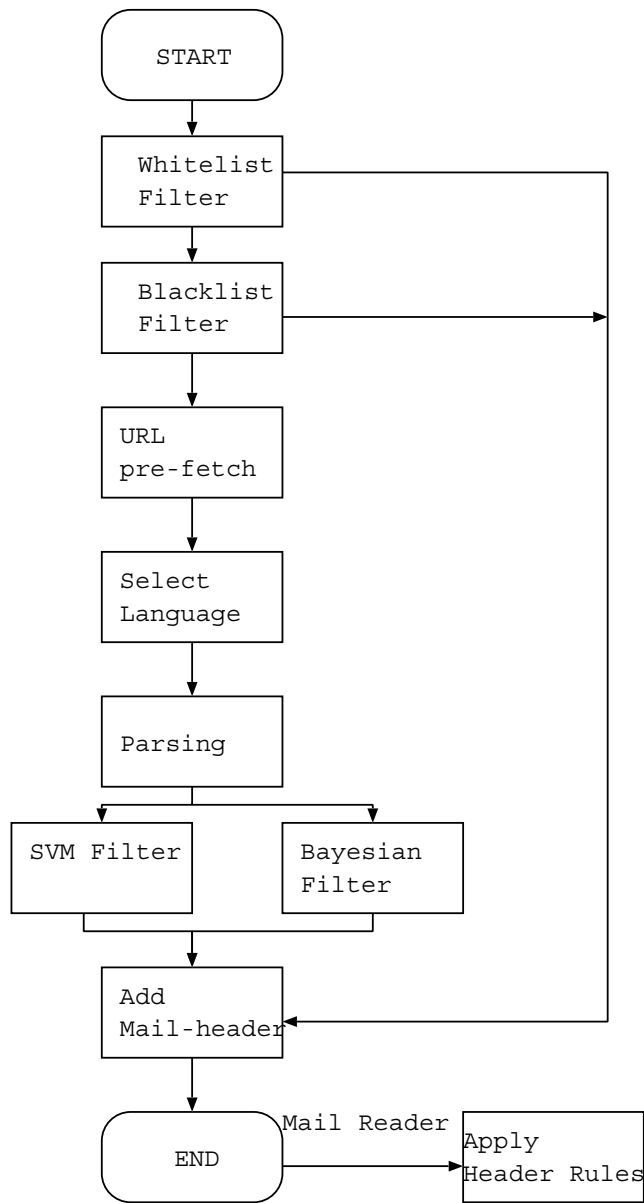

Fig. 1. Flowchart of Combined Spam Filter

We implemented the SVM spam filter, and evaluated the performance. The filter was constructed by using SVM^{light}[5] as implementation of SVM. The stems were extracted by using TreeTagger[6] as English tokens. The stems were extracted by using Chasen[7] as Japanese tokens. The filter was learned by using 921 totals of mails which included 175 Japanese spam mail and 188 Japanese regular mail, 261 English spam mail, and 300 English, regular mail for the experiment.

4 Conclusion and Future Work

In this paper, the system that classified spam mail and other mail(regular mail) was constructed by two filters with Bayesian theory and SVM(Support Vector Machine) used well by the text classification task as a text classification algorithm. It was confirmed to evaluate the performance of the spam filter constructed by Bayesian theory and SVM, and to show a high reproduction ratio and a high relevance ratio. As a result, it can be thought that Bayesian filter and SVM filter are effective as the spam filter. Moreover, the URL pre-fetch method was built into Bayesian spam mail filter, and the relevance ratio was able to be improved. It can be concluded that the performance of the spam mail filter can be improved by building in the URL pre-fetch method from this result.

We proposed the spam filter system by the combination of some filters, and discussed the system that added URL pre-fetch method to Bayesian spam filter and the SVM filter. The performance of the spam filter system that combines each filter is scheduled to be evaluated in the future.

References

1. Paul Graham: A Plan for Spam,
<http://www.paulgraham.com/spam.html>
2. Thorsten Joachims: SVM - Light Support Vector Machine,
<http://svmlight.joachims.org/>
3. K. Ando, Jung-H Ha, Jae-Keun Ahn, Su-Hoon Kang, T. Kitano: Propose New Method for SPAM Mail, Multimedia, Distribution, cooperation and mobile(DICOMO2003) symposium (2003). (In Japanese)
4. nabeken: bsfilter / bayesian spam filter,
<http://www.h2.dion.ne.jp/nabeken/bsfilter/>
5. H. Taira, M. Haruno: Feature Selection in SVM Text Categorization, Journal of Information Processing Society of Japan, Vol.41, No.4,pp.1113-1123 (2000). (In Japanese)
6. IMS Textcorpora and Lexicon Group: TreeTagger,
<http://www.ims.uni-stuttgart.de/projekte/corplex/TreeTagger/>
7. Y. Matsumoto, A. Kitauchi, T. Yamashita, Y. Hirano, H. Matsuda, K. Takaoka, M. Asahara: Morphological Analysis System ChaSen version 2.2.1 Manual (2000). [Online] Available: <http://chasen.aist-nara.ac.jp/chasen/bib.html.en>